

Electromechanical operator for sliding gates



- Range of 24V operators for sliding gate weighing up to 600kg, maximum leaf speed 12m/min.



Technical Features

U-Link	No
Control Unit	HAMAL SL2
Board Power Supply	230V
Motor Power Supply	24V
Power Input	70W
Leaf Weight	600 kg
Leaf Speed	12 m/min
Type of Limit Switch	Electromechanical
Pinion Module	4
Slowdown	Yes
Locking	Mechanical
Release	Lever-operated with personal key
Frequency of Use	Intensive
Environment Conditions	from -20 °C to 55 °C
Protection Rating	IP24
Actuator Weight	8 kg
Impact Reaction	D-Track

Dimensions

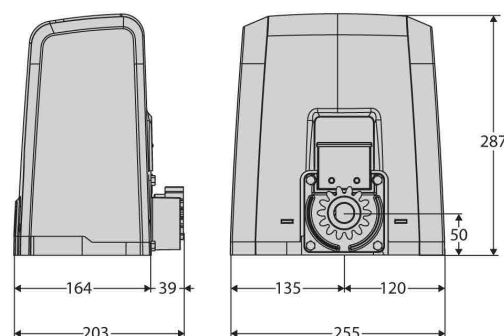

Control Panel

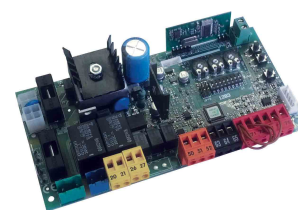

* Design and specifications are subject to change without notice

Accessories



RADIUS B LTA 230 R2
Flashing Light



MITTO B RCB02 R3
Transmitter 2 Channel



SL BAT2
Battery Kit



ERIS A30
Wireless Photocell



B EBA Blue Entry Andriod 4
Blue-Tooth Module